

G-Box Expert GL-5 75W-90

Automotive Gear Oil



Semisynthetic



Drive axles



EP EP properties



Oxidation Stability



Low-temperature properties

G-Box Expert GL-5 75W-90 is high quality gear oil for heavy duty manual transmissions and rear axles where operations require gear lubricants with excellent load-carrying capability over wide operating temperatures and where extreme pressures and shock loading are expected. G-Box Expert GL-5 75W-90 is formulated from a blend of synthetic and highly refined mineral base oils and advanced additive package to provide superior wear protection, excellent low temperature characteristics and high temperature stability when compared to conventional mineral gear oils.

Applications



- Passenger cars, light- and heavy-duty trucks, busses, vans
- Off-highway industries including: construction, quarrying, and agriculture
- Transmissions and axles and other applications where high extreme pressure gear oil meeting API GL-5 are recommended
- Not suitable for automatic, manual, or semi-automatic transmissions for which engine oil or automatic transmission fluids are recommended
- Not suitable for limited slip applications

Features	Advantages and Potential Benefits
Excellent extreme-pressure properties	Increased load-carrying capability for protection against low speed/high torque wear, high speed scoring and spalling
Excellent frictional properties	Improved smooth shifting performance
Improved thermal and oxidation stability	Reduced deposits and sludge build-up for long transmission life
Improved low temperature performance	Oil flows and circulates more quickly at low temperatures to extend transmission life
Rust and corrosion protection	Protection of copper and its alloys for improved gear performance and long component life
Compatible with all common seal materials	Excellent leakages control

Recommendations

- API GL-5

Approvals

- AVTOVAZ

Typical Characteristics

Properties	Method	G-Box Expert GL-5 75W-90
SAE Viscosity Grade	SAE J306	75W-90
Kinematic Viscosity @40°C, mm ² /s	ASTM D445	108,2
Kinematic Viscosity @100°C, mm ² /s	ASTM D445	15,4
Viscosity Index	ASTM D2270	150
Brookfield @-40°C, mPa·s	ASTM D2983	111 000
Flash Point (COC), °C	ASTM D92	205
Pour Point, °C	ASTM D97	-43
Density @15°C, kg/m ³	ASTM D4052	861

ISO 9001

ISO 14001

ISO/TS 16949

OHSAS 18001

CERTIFIED

G-Box Expert GL-5 75W-90 performance benefits

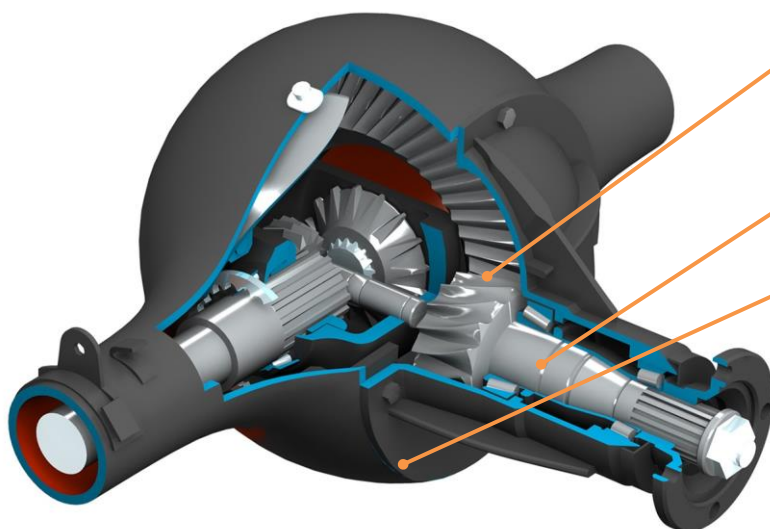

Prolonged gear life

Wear and extreme pressure protection
 – damaged surface area 28% lower (ASTM L-37)
 – damaged surface area of hypoid gear under shock loads 3.8 times lower (ASTM L-42)

Leakage control

Effect on seals materials 5 times lower (VDA 675 301 (70 ACM 121433))

Deposits build-up control

Oxidation stability 2.4 times higher (Oxidation ASTM L-60)

Wear protection under heavy loads*

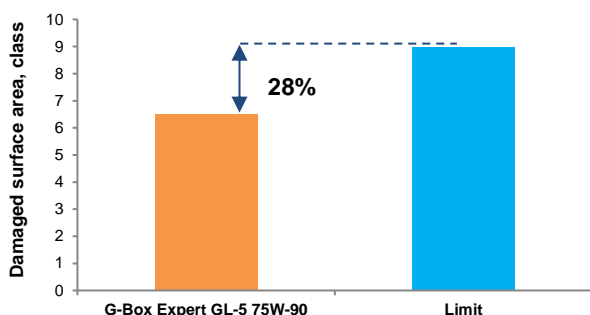

Thermal Stability**

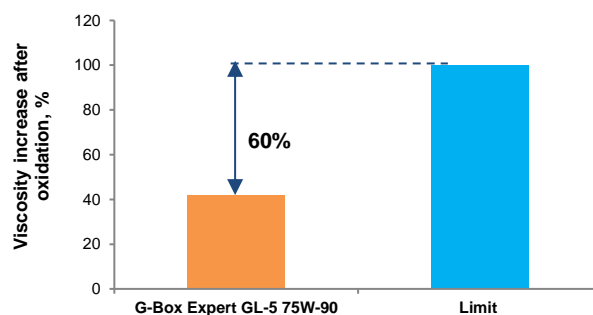

*Tectr ASTM L-37; **Tectr ASTM L-60

Health, Safety & Environment

Information is provided for products in the relevant Safety Data Sheet (SDS). This provides guidance on potential hazards, precautions and first-aid measures, together with environmental effects and disposal of used products. SDS's are available upon request through your sales contract office. This product should not be used for purposes other than its intended use.